

# S-5!<sup>®</sup>

## The Right Way!

### 1. ColorGard<sup>®</sup>

ColorGard<sup>®</sup> snow retention system is manufactured from mill finished high quality aluminum. It comes in 8' long sections, in punched or unpunched configurations. Splices are included with ColorGard for adjacent sections. For use with S-5!<sup>®</sup> standard clamps, VersaBracket<sup>™</sup> and CorruBracket<sup>™</sup>.

### 2. Punched Crossmember

Punched ColorGard is slotted every 4" on center for seams that are spaced accordingly, i.e. divisible by 4". The slotted configuration works well with S-5! clamps.

### 3. Unpunched Crossmember

Unpunched ColorGard is the most versatile and easy to install, when used with the S-5! VersaClip<sup>™</sup>. Unpunched does not need holes, as the VersaClip accommodates any seam spacing. The unpunched configuration works well with VersaBracket, and is the right choice when the roof is laid out with untrue seam width or when the seam width is not divisible by 4. If in any doubt, use unpunched.

### 4. VersaClip<sup>™</sup>

Purchased separately, VersaClip makes installation easy as it simply slides on the ColorGard crossmember. It can be used with all S-5! clamps (one per clamp), and is optional with CorruBracket. VersaClip is not needed with VersaBracket. VersaClip is also handy when installing ColorGard askew, such as is required in the valleys between intersecting rooflines.

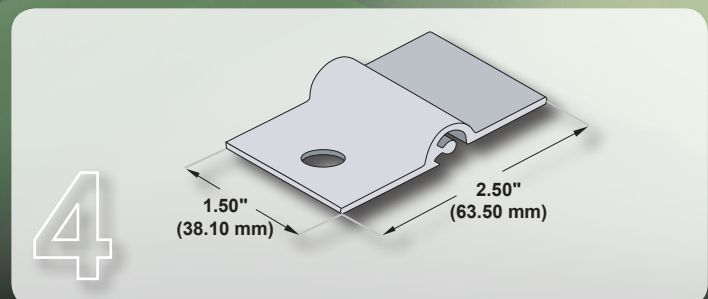
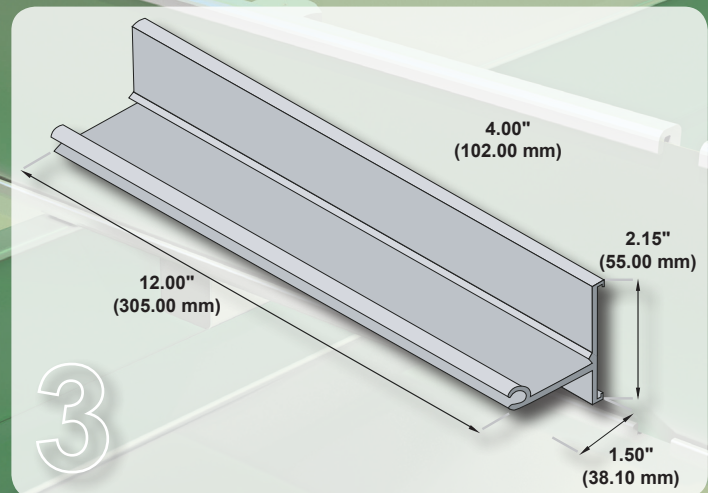
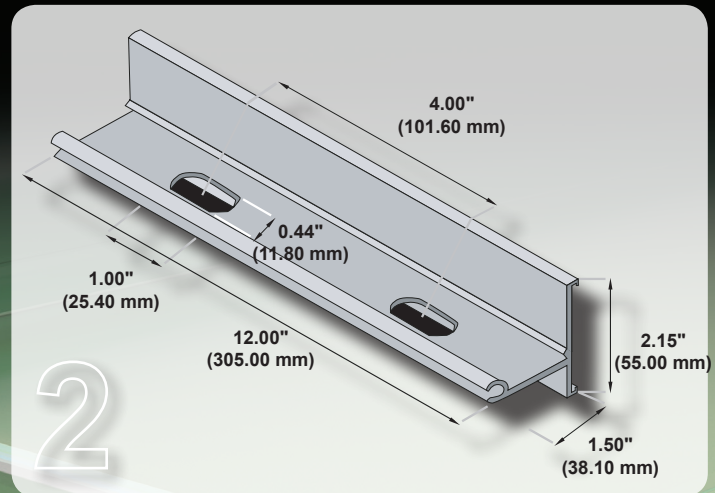
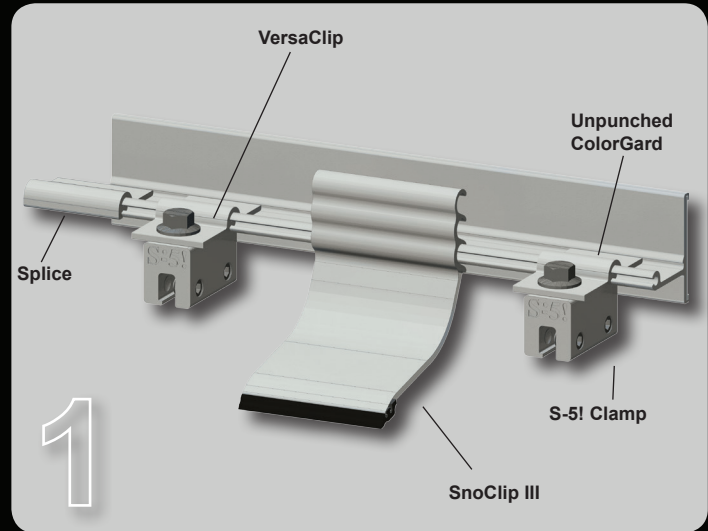

Please note: Bars come in 8' lengths, but shown here in 12" diagrams. All measurements are rounded to the second decimal place.

The right way to attach almost anything to metal roofs!

ColorGard<sup>®</sup> Components

800.284.1412 | www.lmcurbs.com



ColorGuard® dramatically reduces the risks associated with rooftop avalanches and maintains the clean colorful appearance of the roof with perfect color and finish matching, which lasts as long as the roof itself! ColorGuard is the only snow retention system that can be designed and engineered on a site-specific basis.



## ColorGuard®

### Splice

Included with crossmembers. Use the Splice to join two pieces of ColorGuard® together, ensuring continuous, unbroken protection.

The dimple in the center is designed to provide a gap, allowing for expansion and contraction of the ColorGuard sections.

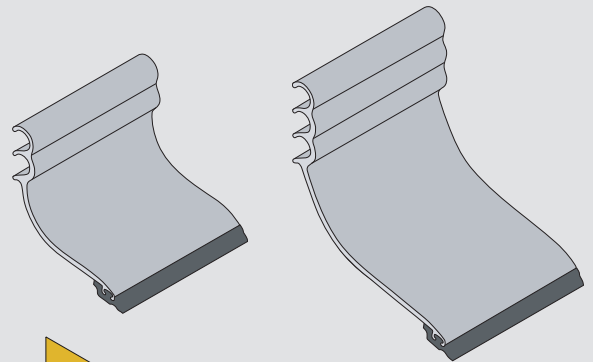
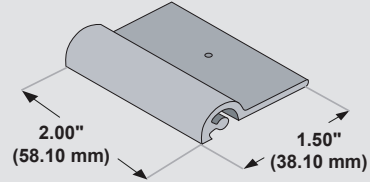

### SnoClip™

SnoClip™ is added to retard the migration of snow and ice beneath the crossmembers. See the SnoClip brochure for more details.

### ColorStrip

Not included. The ColorStrip should be supplied in 2" wide strips by the manufacturer of the roofing material in order to ensure a perfect color match for the life of the roof system.

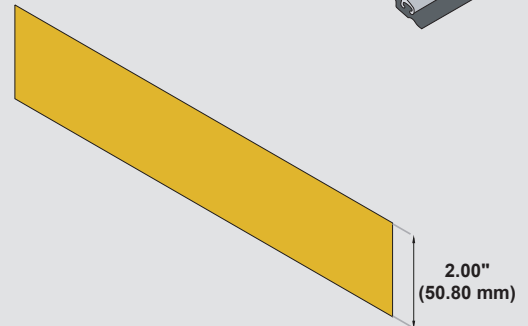

## For use with all these S-5!® products

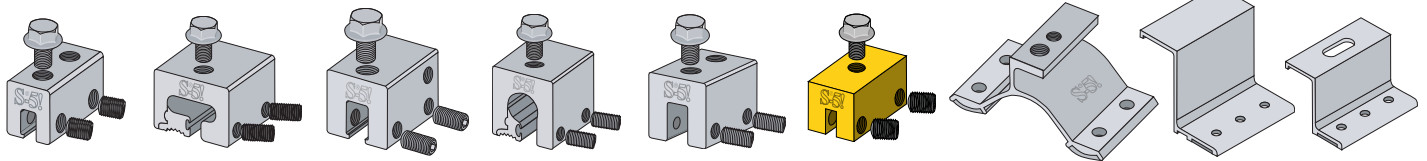

**Note:** Do not use ColorGuard with attachment spacing greater than 32" (81.30 cm). Custom ColorGuard, Splice, and SnoClips are available for seam spacing greater than 32" (81.30 cm). Please inquire through a distributor.

\*See optional limited ColorGuard System Warranty Program information at [www.S-5-ColorGuard.com](http://www.S-5-ColorGuard.com)

Check out our  
ColorGuard®  
Mobile Calculator

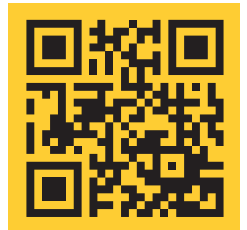

### S-5!® Warning! Please use this product responsibly!

Products are protected by multiple U.S. and foreign patents. Visit the website at [www.S-5.com](http://www.S-5.com) for complete information on patents and trademarks. For maximum holding strength, setscrews should be tensioned and re-tensioned as the seam material compresses. Clamp setscrew tension should be verified using a calibrated torque wrench between 160 and 180 inch pounds when used on 22ga steel, and between 130 and 150 inch pounds for all other metals and thinner gauges of steel. Consult the S-5! website at [www.S-5.com](http://www.S-5.com) for published data regarding holding strength.

Copyright 2014, Metal Roof Innovations, Ltd. S-5! products are patent protected. S-5! aggressively protects its patents, trademarks, and copyrights. Version 032714.

Distributed by



P: 800-284-1412

F: 903-759-3598

W: [www.lmcurbs.com](http://www.lmcurbs.com)