



MODEL CE-XAJ-4
COMBINATION LOUVER EXHAUST
STRAIGHT BLADE

Standard Construction:

- Frame:** 4" x .081 (101 mm x 2.1 mm) extruded aluminum (6063-T5).
- Stationary Blades:** .081 (2.1 mm) extruded aluminum (6063-T5) approximately 4-3/8" (111 mm) on centers.
- Blade Angle:** 45°
- Backdraft Blade:** .025 (6.4 mm) formed aluminum.
- Axles:** 3/16" (4.8 mm) dia. nylon.
- Blade Seals:** Polyurethane foam.
- Screen:** Bird screen - 3/4" x .050 (19 mm x 12.7 mm) flattened expanded aluminum in a removable frame on interior of louver.
- Finish:** Mill aluminum.
- Size:** Minimum: 12"w x 12"h (25.4 mm x 25.4 mm)
 Maximum: Single Section - 36"w x 72"h (914 mm x 1828 mm)
 Multi section - unlimited.

Options:

- Screens:** Insect screen - 18 x 16 mesh aluminum.
 Other: _____
- Finish:** Prime Coat.
 Baked Enamel.
 Clear Anodize - 204-R1 & 215-R1.
 Integral Color Anodize
 Kynar 500 Enamel.
 Other: _____

Sill Extensions:

- Flange:** 1-1/2" (38 mm) (front or rear)

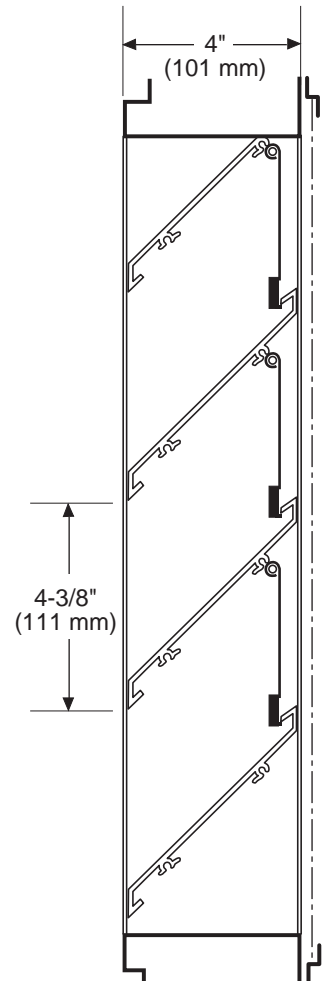

CHANNEL FRAME

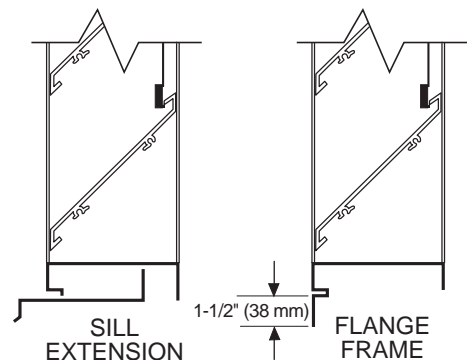
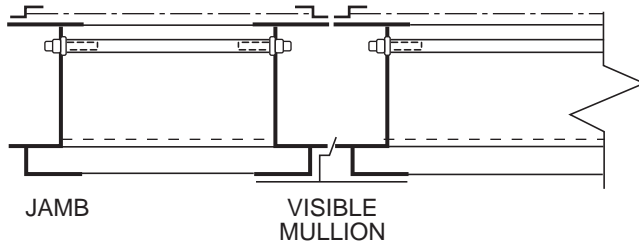

CEXAJ4 - 7-00

Specifications are correct at time of printing. However, as part of our 'continuous improvement program,' we reserve the right to make further improvements without notice.

© JULY, 2000 NCA Manufacturing

Project:
 Location:
 Architect:
 Engineer:

Contractor:
 Address:
 P.O. Number:
 Date: