



**MODEL SLZ-4
FORMED STATIONARY LOUVER
STEP BLADE. AMCA LICENSED.**



Standard Construction:

- Frame:** 4" (101 mm) x 20 ga. galvanized steel.
- Blades:** 20 ga. galvanized steel, approximately 4-3/8" (111 mm) on centers.
- Blade Angle:** 45°
- Screen:** Bird screen - 1/2" x 1/2" (12.7 mm x 12.7 mm) x 19 ga. galvanized steel. In a removable frame on interior of louver.
- Finish:** Mill galvanized.
- Minimum Size:** 10"w x 12"h (254 mm x 304 mm)

Options:

- Screens:** Insect screen - 18 x 16 mesh aluminum.
Other: _____
- Finish:** Prime coat
Baked Enamel
Kynar 500 Enamel
Other: _____

Sill Extensions:

- Flange:** 1-1/2" (38 mm) (front or rear)
- Material:** Various materials and gauges
- Notes:** Louvers fabricated 1/4" (6.4 mm) under opening size unless otherwise noted.

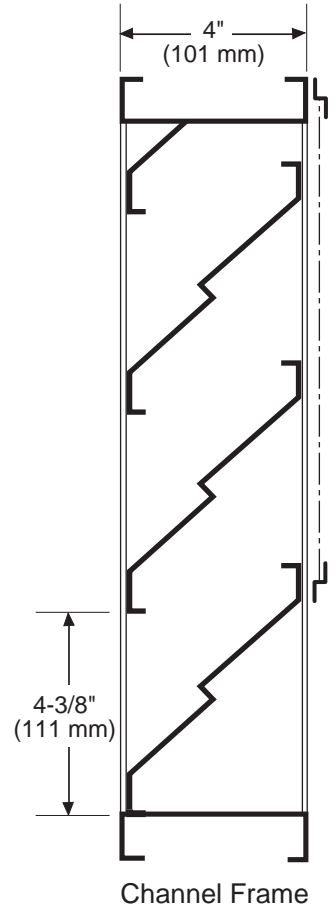

Channel Frame

SLZ4 - 7-00

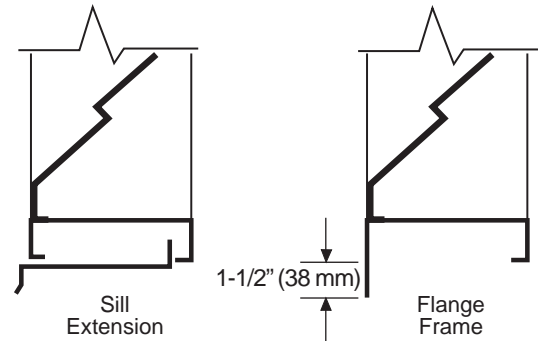
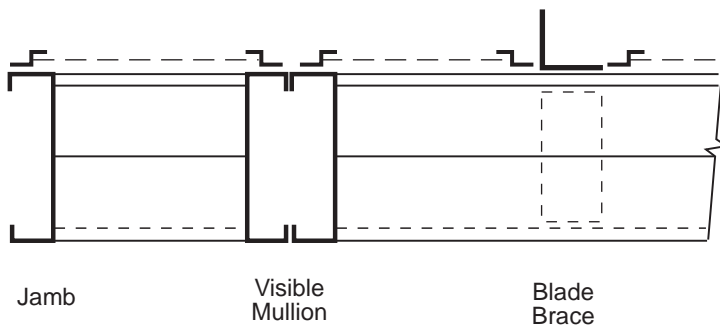

Specifications are correct at time of printing. However, as part of our 'continuous improvement program,' we reserve the right to make further improvements without notice.

© JULY, 2000 NCA Manufacturing

Project: _____ Contractor: _____
 Location: _____ Address: _____
 Architect: _____ P.O. Number: _____
 Engineer: _____ Date: _____



MODEL SLZ-4 LOUVER PERFORMANCE DATA

STEP BLADE. FORMED STEEL. AMCA LICENSED.

© JULY, 2000 NCA Manufacturing

Furnish and install where shown model **SLZ-4** Louver, manufactured by **NCA Manufacturing**. Louver shall be the **stationary** step blade type with a frame depth of **4"** inches. Frame and blades shall be 20 gauge galvanized steel. Blades shall be located on a 45 degree blade angle. Screen shall consist of 1/2" mesh, 19 gauge galvanized with an extruded aluminum frame, mounted to the louvers interior and be removable for cleaning. Louvers shall be finished with Polyurethane Acrylic Enamel, Kynar 500, or another finish selected by the architect from NCA Standard Color Chart.

SLZ-4 Free Area in Sq. Ft.

Height – Inches	Width – Inches														
	12	18	24	30	36	42	48	54	60	66	72	78	84	90	96
12	.18	.28	.39	.50	.61	.71	.82	.93	1.04	1.15	1.25	1.34	1.45	1.55	1.66
18	.43	.70	.97	1.24	1.51	1.77	2.04	2.31	2.58	2.84	3.11	3.32	3.59	3.86	4.13
24	.60	.97	1.34	1.70	2.07	2.44	2.81	3.18	3.55	3.92	4.28	5.31	5.74	6.16	6.59
30	.81	1.31	1.80	2.30	2.80	3.29	3.79	4.29	4.79	5.28	5.78	6.17	6.67	7.17	7.66
36	1.05	1.69	2.34	2.98	3.63	4.27	4.92	5.56	6.21	6.85	7.50	8.16	8.81	9.47	10.13
42	1.20	1.93	2.67	3.41	4.15	4.88	5.62	6.36	7.09	7.83	8.57	10.14	10.96	11.78	12.59
48	1.44	2.33	3.21	4.10	4.99	5.87	6.76	7.65	8.53	9.42	10.31	11.01	11.89	12.78	13.67
54	1.65	2.66	3.67	4.69	5.70	6.71	7.73	8.74	9.76	10.77	11.78	12.99	14.04	15.09	16.13
60	1.81	2.93	4.05	5.16	6.28	7.39	8.51	9.63	10.74	11.86	12.97	13.86	14.97	16.09	17.21
66	2.07	3.35	4.63	5.90	7.18	8.45	9.73	11.01	12.28	13.56	14.83	15.84	17.12	18.40	19.67
72	2.25	3.63	5.01	6.39	7.77	9.16	10.54	11.92	13.30	14.69	16.07	17.83	19.26	20.70	22.14
78	2.45	3.95	5.46	6.96	8.47	9.97	11.48	12.99	14.49	16.00	17.50	18.69	20.20	21.70	23.21
84	2.70	4.35	6.01	7.67	9.33	10.99	12.65	14.30	15.96	17.62	19.28	20.68	22.34	24.01	25.67
90	2.84	4.60	6.35	8.10	9.85	11.60	13.35	15.10	16.85	18.60	20.35	33.66	24.49	26.31	28.14
96	3.08	4.97	6.87	8.76	10.66	12.55	14.45	16.34	18.24	20.13	22.03	23.53	25.42	27.32	29.21

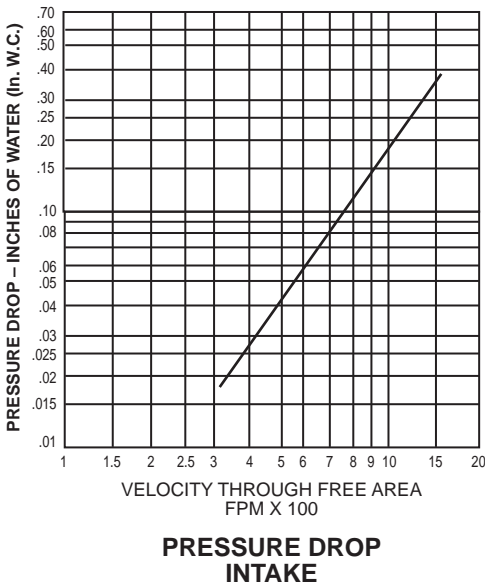

NCA Manufacturing, Inc. certifies that the Model SLZ-4 louver shown herein is licensed to bear the AMCA seal. The ratings shown are based on tests and procedures performed in accordance with AMCA Publication 511 and comply with the requirements of the AMCA Certified Ratings program.

The AMCA Certified Seal applies to air performance ratings and water penetration ratings.

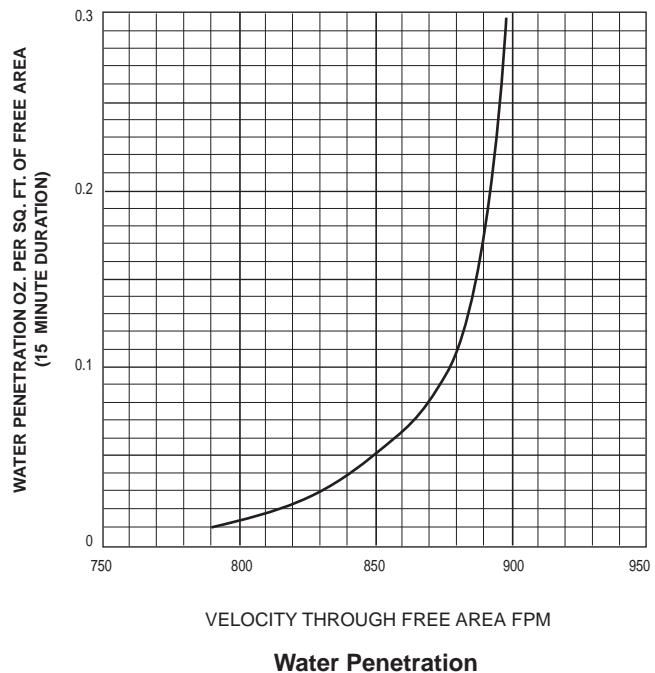

Water Penetration Data applies to test unit size 48" x 48" only. Beginning of Water Penetration is 790 FPM Free Area Velocity.