



*MODEL A-SLD-4-45-GL  
FORMED ADJUSTABLE LOUVER  
DRAINABLE BLADE*

**Standard Construction:**

- Frame:** 4" (101 mm) x 20 ga. galvanized steel.
- Blades:** 20 ga. galvanized steel, approximately 4-1/2" (114 mm) on centers.
- Blade Angle:** 45°
- Bearings:** Permanently lubricated oilite bronze, press fit into frame.
- Axes:** 1/2" (12.7 mm) dia. plated steel.
- Linkage:** Plated steel, concealed in jamb.
- Operator:** Wing nut slide bracket.
- Screen:** Bird screen - 1/2" x 1/2" (12.7 mm x 12.7 mm) x 19 ga. galvanized steel, in a removable frame on interior of louver.

- Finish:** Mill galvanized.
- Minimum Size:** 12"w x 12"h (25.4 mm x 25.4 mm)
- Maximum Section Size:** 48"w x 72"h (1219 mm x 1829 mm) with Jamb Seal  
48"w x 96"h (1219 mm x 2438 mm) without Jamb Seal

**Options:**

- Screens:** Insect screen - 18"w x 16"h (457 mm x 406 mm) mesh aluminum.  
Other: \_\_\_\_\_
- Blade Seals:** Extruded vinyl
- Jamb Seals:** Flexible stainless steel
- Finish:** Prime Coat.  
Baked Enamel.  
Kynar 500 Enamel.  
Other: \_\_\_\_\_
- Sill Extensions:**
- Flange:** 1-1/2" (38 mm) (front or rear)
- Other Operator** - \_\_\_\_\_
- Notes:** Louvers fabricated 1/4" (6.4 mm) under opening size unless otherwise noted.

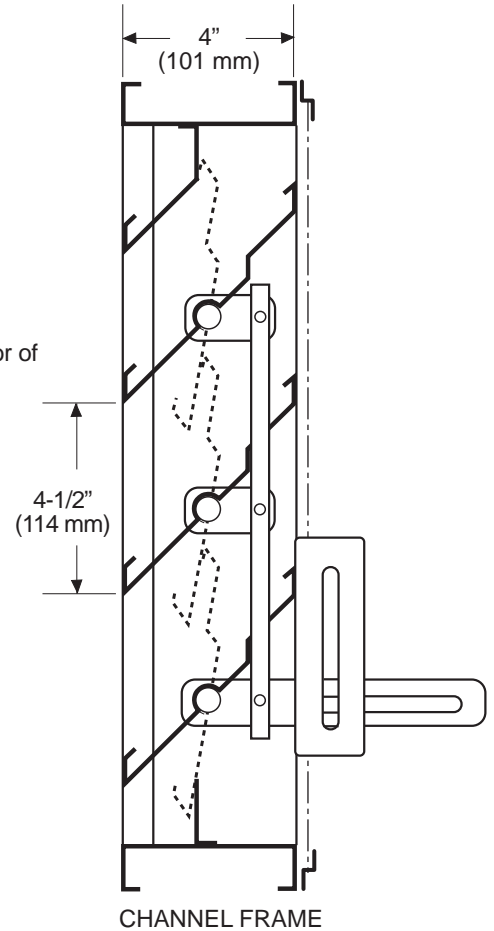

ASLD-4-45-GL - 02-05

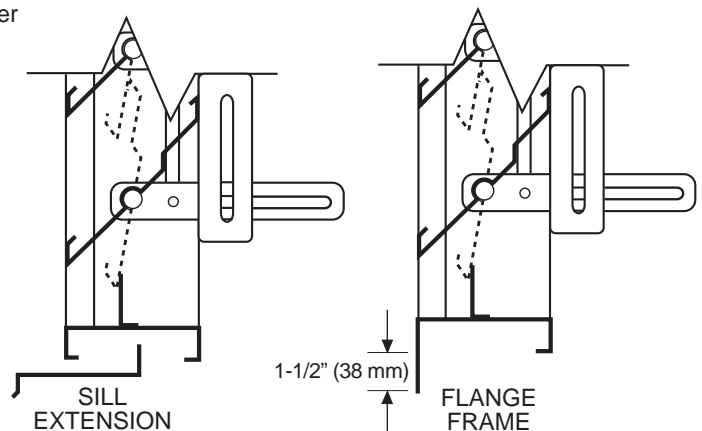
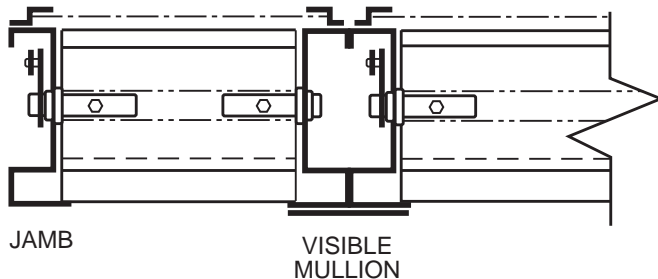

Specifications are correct at time of printing. However, as part of our 'continuous improvement program,' we reserve the right to make further improvements without notice.  
© JULY, 2000 NCA Manufacturing

Project:	Contractor:
Location:	Address:
Architect:	P.O. Number:
Engineer:	Date:



# MODEL A-SLD-4-45-GL FORMED ADJUSTABLE LOUVER DRAINABLE BLADE

## PERFORMANCE DATA

© JULY, 2000 NCA Manufacturing

### Specifications

Furnish and install where shown model **A-SLD-4-45-GL** louver, manufactured by **NCA Manufacturing**. Louvers shall be the **drainable blade** type with a frame depth of **4 inches**. Frames and blades shall be 20 gauge galvanized aluminum. Blades shall be located on a **45 degree** blade angle. Screens shall consist of 1/2" 19 gauge galvanized aluminum, with an extruded frame, mounted to the louver interior, and be removable for cleaning. Louvers shall be finished with Polyurethane Acrylic enamel, Kynar 500, or other finishes selected by the architect from NCA standard color charts.

### A-SLD-4-45-GL Free Area in Sq. Ft.

		Width – Inches														
		12	18	24	30	36	42	48	54	60	66	72	78	84	90	96
Height – Inches	12	0.33	0.55	0.77	0.34	0.42	0.49	0.57	0.64	0.72	0.79	0.87	0.94	1.02	1.10	1.17
	18	0.60	1.00	1.40	0.94	1.15	1.36	1.57	1.78	1.99	2.20	2.41	2.62	2.83	3.04	3.25
	24	0.76	1.27	1.77	1.55	1.89	2.24	2.58	2.93	3.27	3.61	3.96	4.30	4.65	4.99	5.33
	30	1.03	1.71	2.40	2.15	2.63	3.11	3.59	4.07	4.55	5.02	5.50	5.98	6.46	6.94	7.42
	36	1.30	2.16	3.03	2.76	3.37	3.98	4.60	5.21	5.82	6.43	7.05	7.66	8.27	8.89	9.50
	42	1.46	2.43	3.41	3.36	4.11	4.86	5.60	6.35	7.10	7.85	8.59	9.34	10.09	10.83	11.58
	48	1.27	2.11	3.09	3.97	4.85	5.73	6.61	7.49	8.37	9.26	10.14	11.02	11.90	12.78	13.66
	54	2.00	3.33	3.56	4.57	5.59	6.60	7.62	8.63	9.65	10.67	11.68	12.70	13.71	14.73	15.75
	60	2.16	3.60	4.03	5.18	6.33	7.48	8.63	9.78	10.93	12.08	13.23	14.38	15.53	16.68	17.83
	66	2.43	4.05	4.50	5.78	7.06	8.35	9.63	10.92	12.20	13.49	14.77	16.06	17.34	18.63	19.91
	72	2.70	4.50	4.97	6.38	7.80	9.22	10.64	12.06	13.48	14.90	16.32	17.74	19.15	20.57	21.99
	78	2.86	4.77	5.44	6.99	8.54	10.10	11.65	13.20	14.76	16.31	17.86	19.41	20.97	22.52	24.07
	84	3.13	5.21	5.91	7.59	9.28	10.97	12.66	14.34	16.03	17.72	19.41	21.09	22.78	24.47	26.16
	90	3.40	5.66	6.38	8.20	10.02	11.84	13.66	15.49	17.31	19.13	20.95	22.77	24.60	26.42	28.24
96	3.56	5.93	6.85	8.80	10.76	12.72	14.67	16.63	18.58	20.54	22.50	24.45	26.41	28.36	30.32	

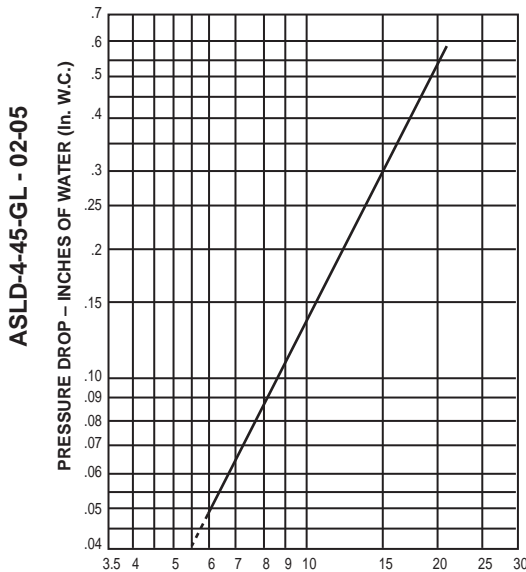

The ratings shown are based on tests and procedures performed in accordance with AMCA Publication 500-L.

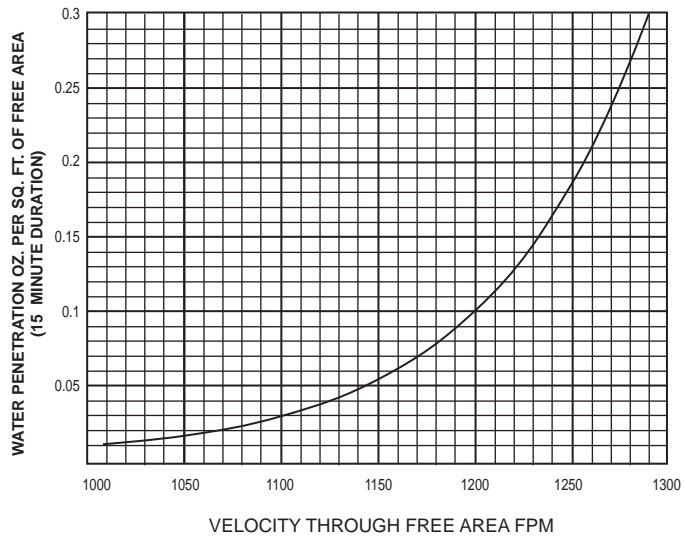

### Water Penetration

Water Penetration Data applies to test unit size 48" x 48" only. Beginning of Water Penetration is 1007 FPM Free Area Velocity. Performance shown is at standard air density 0.075 lbs./ft<sup>3</sup>.