



# S-5!<sup>®</sup>

The Right Way!

The strength of the S-5-KHD clamp is in its simple design. The patented setscrews will slightly dimple the metal seam material but not pierce it—leaving roof warranties intact.

The S-5-KHD clamp is furnished with the hardware shown to the right. Each box also includes a bit tip for tightening the four setscrews using an electric screw gun. A structural aluminum attachment clamp, the S-5-KHD is compatible with most common metal roofing materials excluding copper. All included hardware is stainless steel. Please visit [www.S-5.com](http://www.S-5.com) for more information including CAD details, metallurgical compatibilities and specifications.

The S-5-KHD clamp has been tested for load-to-failure results on a variety of relevant profiles from leading manufacturers of panels. The independent lab test reports found on our website at [www.S-5.com](http://www.S-5.com) prove that S-5!<sup>®</sup> holding strength is unmatched in the industry.

## S-5-KHD Insert Options

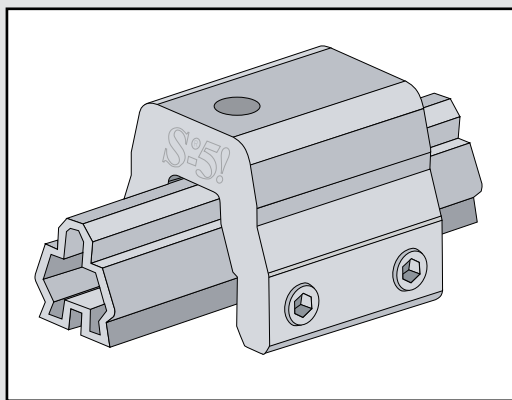
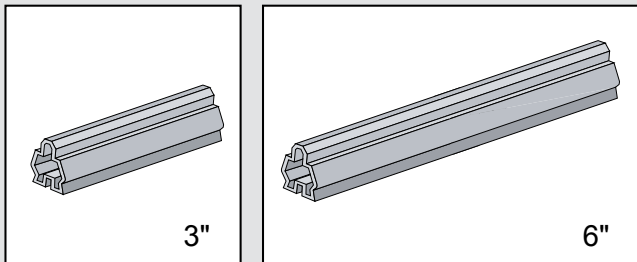

## S-5-KHD Clamp

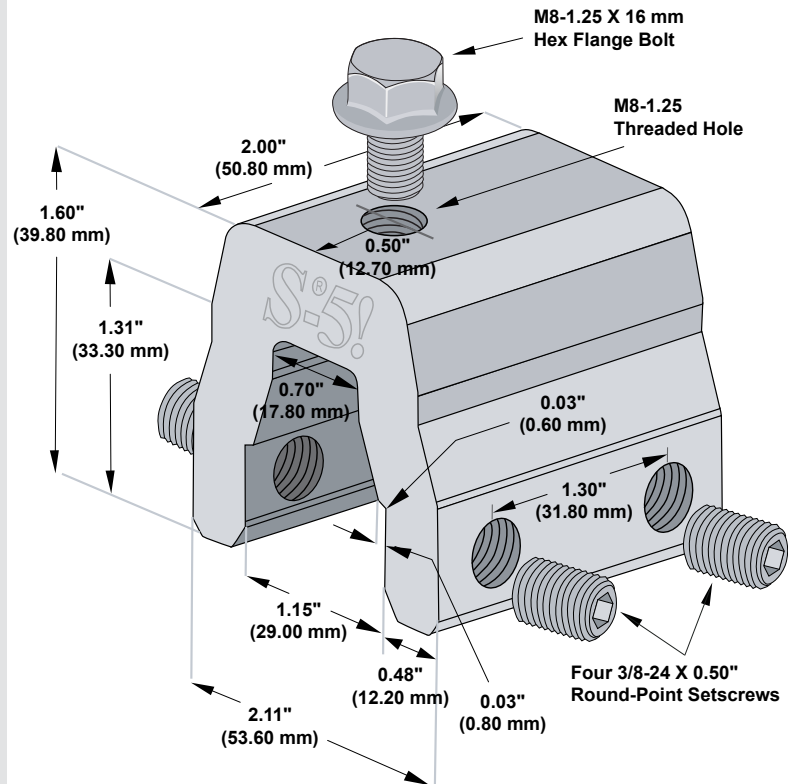

Please note: All measurements are rounded to the second decimal place.

## Example Profile

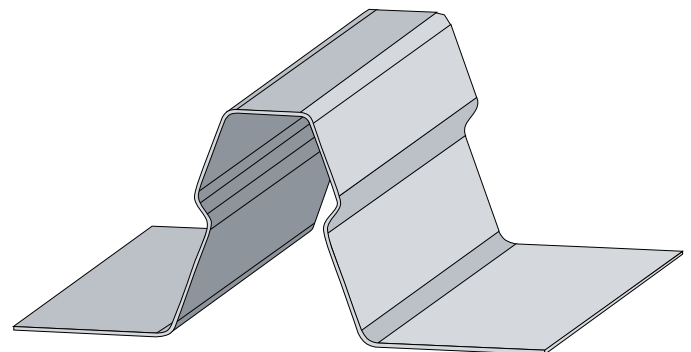

### S-5!<sup>®</sup> Warning! Please use this product responsibly!

Products are protected by multiple U.S. and foreign patents. Visit the website at [www.S-5.com](http://www.S-5.com) for complete information on patents and trademarks. For maximum holding strength, setscrews should be tensioned and re-tensioned as the seam material compresses. Clamp setscrew tension should be verified using a calibrated torque wrench between 160 and 180 inch pounds when used on 22ga steel, and between 130 and 150 inch pounds for all other metals and thinner gauges of steel. Consult the S-5!<sup>®</sup> website at [www.S-5.com](http://www.S-5.com) for published data regarding holding strength.

Copyright 2015, Metal Roof Innovations, Ltd. S-5!<sup>®</sup> products are patent protected. S-5!<sup>®</sup> aggressively protects its patents, trademarks, and copyrights. Version 052115.

Distributed by

P: 800-284-1412

F: 903-759-3598

W: [www.lmcuibs.com](http://www.lmcuibs.com)