

S-5![®]

The Right Way![®]

S-5-NH 1.5 Clamp

The NH 1.5 is part of the "N" line of clamps developed for nail strip profiles. Designed specifically for 1-1/2" nail strip profiles with a wider horizontal dimension - ($> 0.475"$ and $\leq 0.800"$), the S-5-NH 1.5 is an ideal mounting solution for VicWest Prestige, NewTech FF150 and similarly-dimensioned profiles.

The NH 1.5 features an innovative "hinge" insert to allow for a superior fit on new and wider nail strip profiles, as well as older ones. The insert is designed with a toe that engages the female portion of the panel and forms to the shape of the seam to prevent damage, while offering optimal holding strength. Choose the NH 1.5 for heavy, load-critical applications such as snow retention.

S-5-NH 1.5 Mini Clamp

The S-5-NH 1.5 Mini offers the same benefits as its standard counterpart but is smaller with one setscrew, rather than two. Choose the Mini to attach various rooftop accessories, such as solar arrays, satellite dishes, lightning protection systems, antennas, rooftop lighting, conduit, condensate lines and other lighter load applications.*

*S-5! Mini clamps are not compatible with, and should not be used with S-5! SnoRail™/SnoFence™ or ColorGard® snow retention systems.

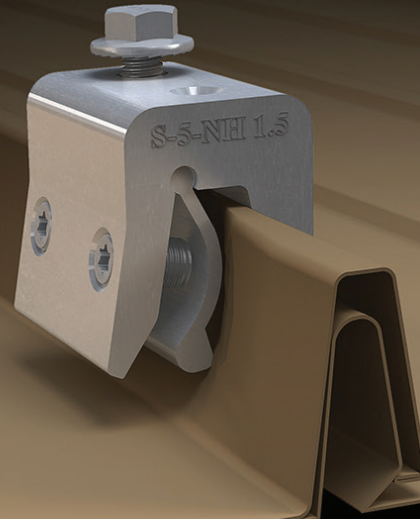

FEATURES AND BENEFITS

- **Angled T-30 Torx setscrews for ease of installation**
- **Fits nail strip profiles w/ base of rib dimension $\leq 0.800"$**
- **Hinge forms to shape of seam, preventing damage at the point of attachment**
- **Reversible hinge for wide & medium-width profiles**
- **Staked hinge insert to facilitate installation**

For nail strip profiles with 1" seam height, see "S-5-N". See also the "S-5-N 1.5" for nail flange metal roof profiles with a seam base dimension $\leq .50"$ (12.7 mm).

The right way to attach almost anything to metal roofs!

S-5-NH 1.5 and S-5-NH 1.5 Mini



800-284-1412 | www.lmcurbs.com



The new and improved S-5-NH 1.5 features an innovative reversible hinged insert that ensures a superior fit for new and wider nail strip profiles.

The S-5-NH 1.5 and S-5-NH 1.5 Mini clamps are each supplied with 300 series stainless steel hardware, pictured on the right. Each box also includes a bit tip for tightening setscrews using an electric screw gun. The S-5-NH 1.5 is a structural aluminum attachment clamp, compatible with most common metal roofing materials (excluding copper). Please visit www.S-5.com for more information including CAD details, metallurgical compatibilities and specifications.

S-5!® holding strength is unmatched in the industry.

S-5-NH 1.5 Clamp

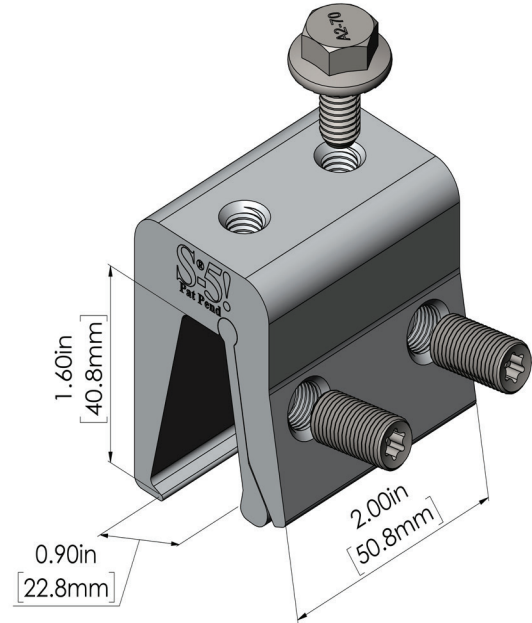

T-30 Torx setscrews included with the standard S-5-NH 1.5 clamp.

S-5-NH 1.5 Mini Clamp

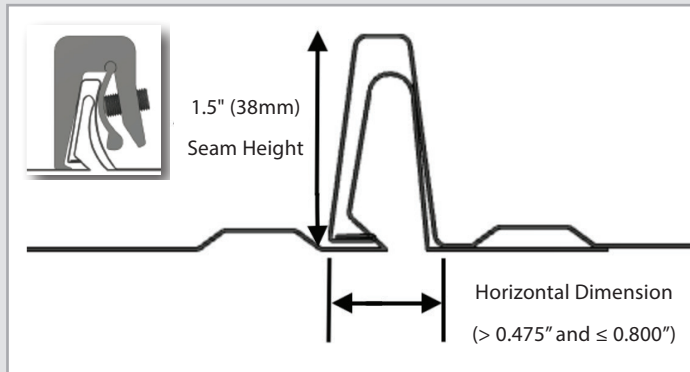
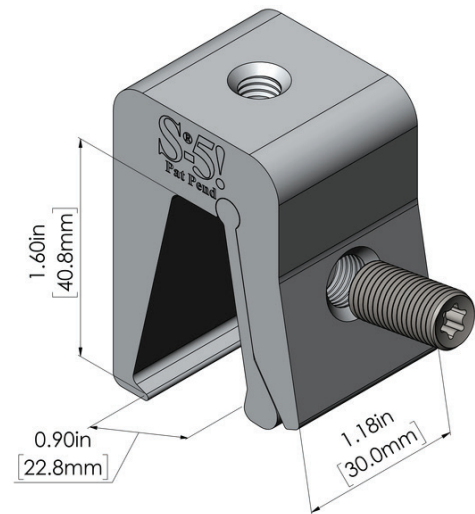

Installation Simplified

The S-5-NH 1.5 is as quick and easy to install as other S-5! clamps. The T-30 Torx setscrews are angled to facilitate tool insertion and improve driver bit withdrawal after screw tensioning. The hinged insert is also staked at one end to hold it in place during installation. It is reversible to allow for proper fit on both wide and medium-width profiles. Choose the S-5-NH 1.5 for a non-penetrating solution that protects the roof, while providing excellent holding strength.

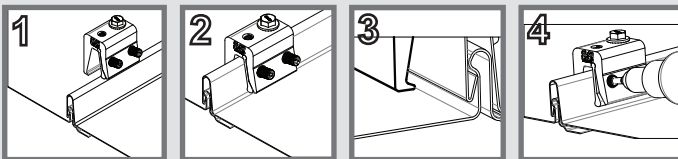

S-5!® Warning! Please use this product responsibly!

Products are protected by multiple U.S. and foreign patents. Visit the website at www.S-5.com for complete information on patents and trademarks. For maximum holding strength, setscrews should be tensioned and re-tensioned as the seam material compresses. Clamp setscrew tension should be verified using a calibrated torque wrench between 160 and 180 inch pounds when used on 22ga steel, and between 130 and 150 inch pounds for all other metals and thinner gauges of steel. Consult the S-5! website at www.S-5.com for published data regarding holding strength.

Copyright 2021, Metal Roof Innovations, Ltd. S-5! products are patent protected. S-5! aggressively protects its patents, trademarks, and copyrights. Version 081621.

Distributed by



827 Fisher Rd.
Longview, TX 75604

903.759.3598 fax