

# KStrong® IMPACT™ Removable Shuttle (Column / Wall and Roof Mount HLL Systems ONLY)

Model: UFF119300

## DESIGN

• The openable stainless steel carriage body is used to secure the user's shock-absorbing Lanyard/Retractable Block to the lifeline. Its design ensures it moves seamlessly and without interruption along the entire horizontal line.

## MATERIAL

Stainless Steel - 316

## FINISH

Electropolished / E Coated

## VITAL TEST COMPLIANCE

Static Strength: 15 kN for 3 Minutes

## WEIGHT

0.46 lbs. ± 0.04 lbs. (212gm ± 10gm)

## RELEVANT STANDARDS

Meets or Exceeds EN 795 : 2012 Type B

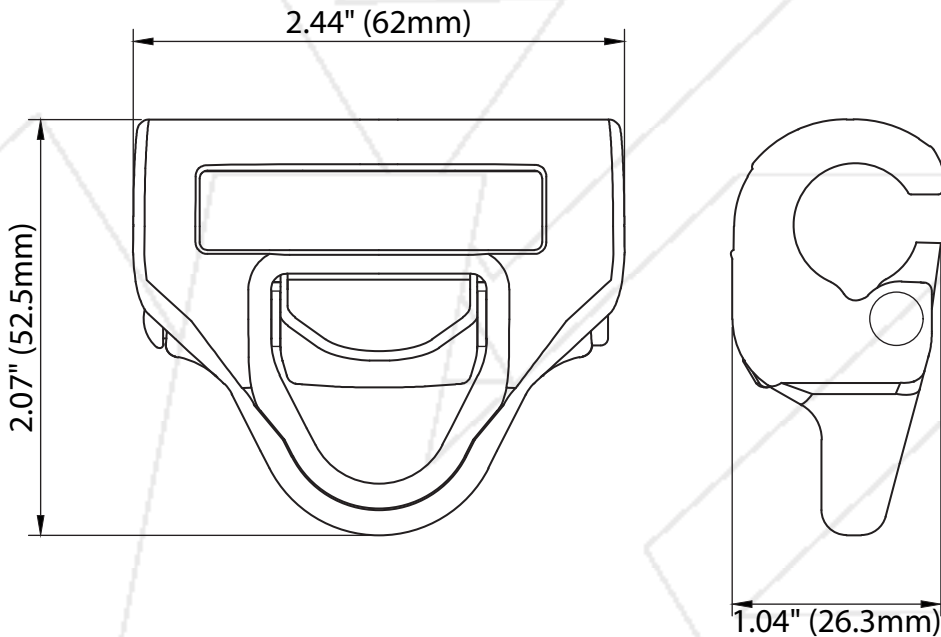
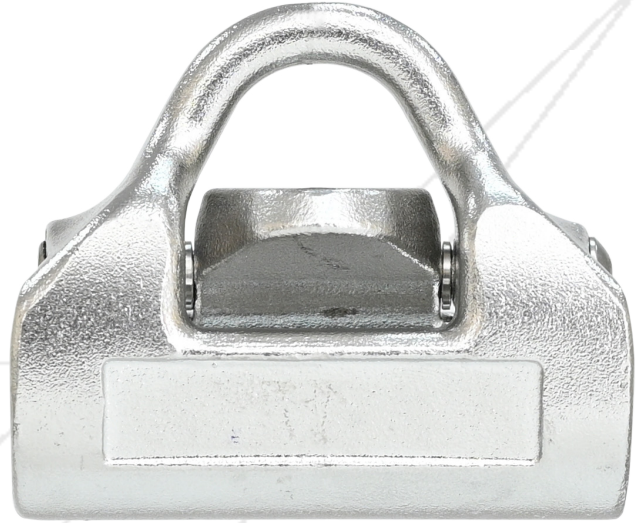

Batch #: \_\_\_\_\_ Serial #: \_\_\_\_\_  
Date of First Use: \_\_\_\_\_