

# S-5!<sup>®</sup>

## The Right Way

### MLPE Mount<sup>™</sup>



**Secure and bond microinverters and power optimizers to solar PV panel frames.**

The MLPE Mount provides a cost-effective, versatile method to attach module level power electronics (MLPE) directly to module frames.

This provides the versatility needed to better handle module-to-module wire management and electrically bonds the equipment together to easily comply with grounding requirements.

#### Installation Flexibility

Install MLPEs before lifting the modules on the roof to save time. Easily adjust the mount if needed when on the roof.

A unique tab feature makes installation quick and easy; securing MLPEs in-place as the mount is tightened. And with a 304 stainless steel body and fastener, there are no corrosion issues to worry about.

Ideal for use with all S-5!'s solar attachments, the MLPE Mount can be used in rail-based installations or can be paired with the PVKIT<sup>®</sup> rail-less solar mounting solution for direct attachment to metal roofs.



MLPE Mount

## Features & Benefits

- Attaches MLPE devices along
- Bonds MLPE to module frame - UL 2703 approval pending
- 304 stainless steel body & fastener
- Tab design aligns w/ MLPE metal bracket slot, easing installation

800-284-1412 | [www.lmcurbs.com](http://www.lmcurbs.com) |



The Right Way!<sup>®</sup> to attach almost anything to metal roofs!



# A Cost-Effective & Versatile Method to Attach Module Level Power Electronics (MLPE) Directly to Solar PV Module Frames

**MLPE Mount™** is compatible with common metal roofing materials.

For design assistance, ask your distributor or visit [www.S-5.com](http://www.S-5.com) for independent lab test data that can be used for load-critical designs and applications. Also, please visit our website for more information, including metallurgical compatibilities and specifications.

**S-5!® holding strength is unmatched in the industry.**

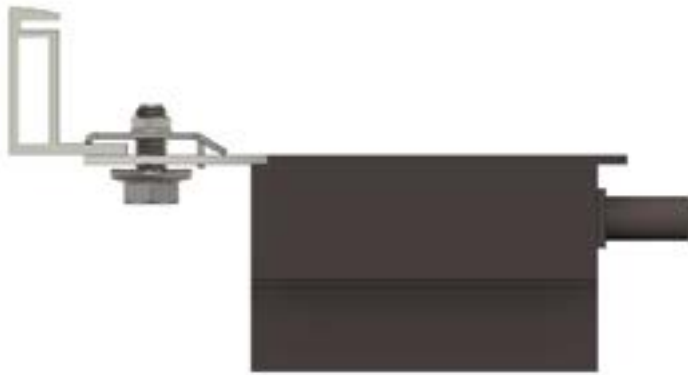

## MLPE Mount™

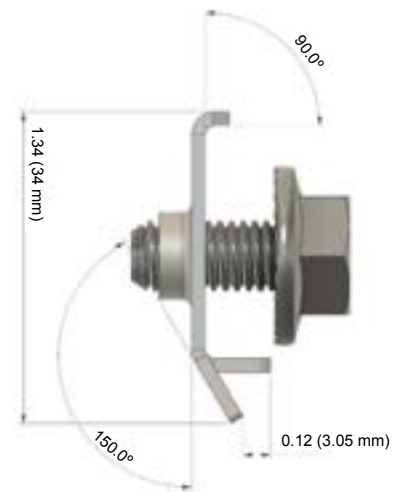
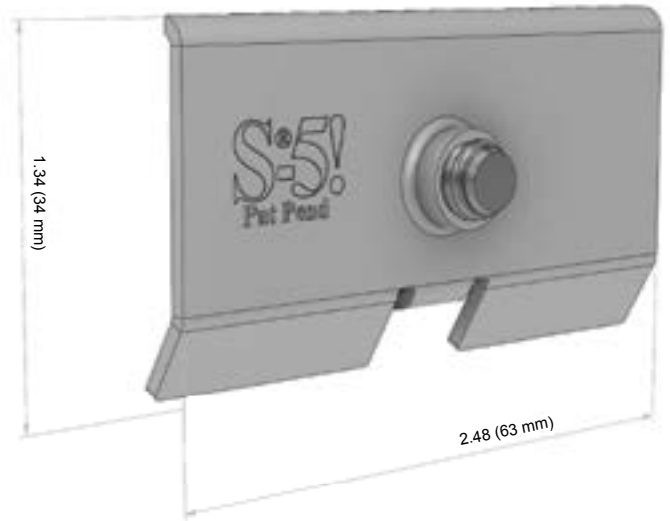

### S-5!® Warning! Please use this product responsibly!

For published data regarding holding strength, bolt torque, patents, and trademarks, visit the S-5! website at [www.S-5.com](http://www.S-5.com).

Copyright 2025, Metal Roof Innovations, Ltd. S-5! aggressively protects its products, patents, trademarks, and copyrights. v. 111025

Distributed by



827 Fisher Rd.  
Longview, TX 75604

903.759.3598 fax